

**ISUZU**  
TRUCK

# N-SERIES DIESEL WALKAROUND

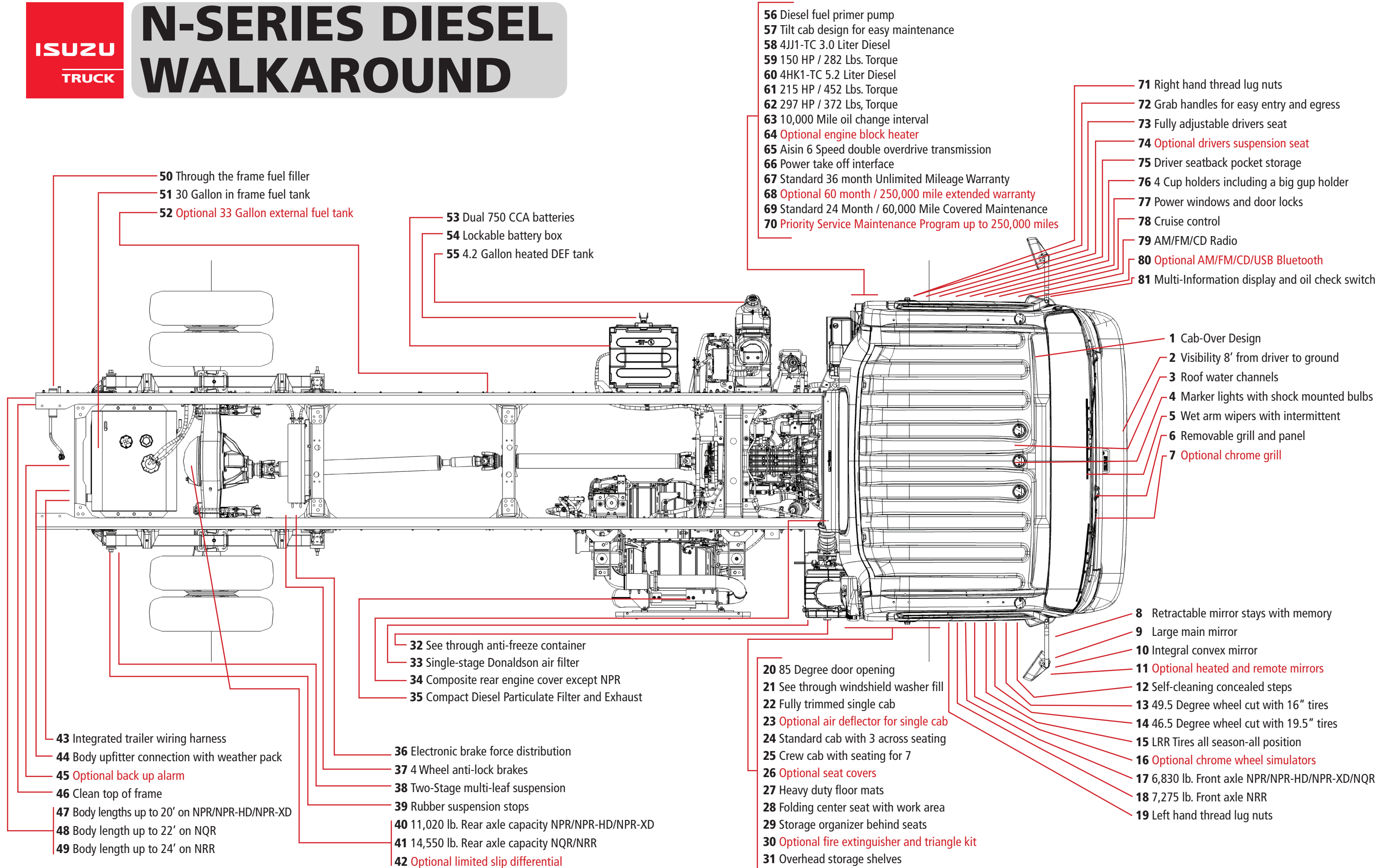

- 50 Through the frame fuel filler
- 51 30 Gallon in frame fuel tank
- 52 Optional 33 Gallon external fuel tank

- 53 Dual 750 CCA batteries
- 54 Lockable battery box
- 55 4.2 Gallon heated DEF tank

- 56 Diesel fuel primer pump
- 57 Tilt cab design for easy maintenance
- 58 4JJ1-TC 3.0 Liter Diesel
- 59 150 HP / 282 Lbs. Torque
- 60 4HK1-TC 5.2 Liter Diesel
- 61 215 HP / 452 Lbs. Torque
- 62 297 HP / 372 Lbs. Torque
- 63 10,000 Mile oil change interval
- 64 Optional engine block heater
- 65 Aisin 6 Speed double overdrive transmission
- 66 Power take off interface
- 67 Standard 36 month Unlimited Mileage Warranty
- 68 Optional 60 month / 250,000 mile extended warranty
- 69 Standard 24 Month / 60,000 Mile Covered Maintenance
- 70 Priority Service Maintenance Program up to 250,000 miles

- 71 Right hand thread lug nuts
- 72 Grab handles for easy entry and egress
- 73 Fully adjustable drivers seat
- 74 Optional drivers suspension seat
- 75 Driver seatback pocket storage
- 76 4 Cup holders including a big gup holder
- 77 Power windows and door locks
- 78 Cruise control
- 79 AM/FM/CD Radio
- 80 Optional AM/FM/CD/USB Bluetooth
- 81 Multi-Information display and oil check switch

- 1 Cab-Over Design
- 2 Visibility 8' from driver to ground
- 3 Roof water channels
- 4 Marker lights with shock mounted bulbs
- 5 Wet arm wipers with intermittent
- 6 Removable grill and panel
- 7 Optional chrome grill

- 8 Retractable mirror stays with memory
- 9 Large main mirror
- 10 Integral convex mirror
- 11 Optional heated and remote mirrors
- 12 Self-cleaning concealed steps
- 13 49.5 Degree wheel cut with 16" tires
- 14 46.5 Degree wheel cut with 19.5" tires
- 15 LRR Tires all season-all position
- 16 Optional chrome wheel simulators
- 17 6,830 lb. Front axle NPR/NPR-HD/NPR-XD/NQR
- 18 7,275 lb. Front axle NRR
- 19 Left hand thread lug nuts

- 32 See through anti-freeze container
- 33 Single-stage Donaldson air filter
- 34 Composite rear engine cover except NPR
- 35 Compact Diesel Particulate Filter and Exhaust

- 20 85 Degree door opening
- 21 See through windshield washer fill
- 22 Fully trimmed single cab
- 23 Optional air deflector for single cab
- 24 Standard cab with 3 across seating
- 25 Crew cab with seating for 7
- 26 Optional seat covers
- 27 Heavy duty floor mats
- 28 Folding center seat with work area
- 29 Storage organizer behind seats
- 30 Optional fire extinguisher and triangle kit
- 31 Overhead storage shelves

- 43 Integrated trailer wiring harness
- 44 Body upfitter connection with weather pack
- 45 Optional back up alarm
- 46 Clean top of frame
- 47 Body lengths up to 20' on NPR/NPR-HD/NPR-XD
- 48 Body length up to 22' on NQR
- 49 Body length up to 24' on NRR

- 36 Electronic brake force distribution
- 37 4 Wheel anti-lock brakes
- 38 Two-Stage multi-leaf suspension
- 39 Rubber suspension stops
- 40 11,020 lb. Rear axle capacity NPR/NPR-HD/NPR-XD
- 41 14,550 lb. Rear axle capacity NQR/NRR
- 42 Optional limited slip differential

# N-SERIES GAS WALKAROUND

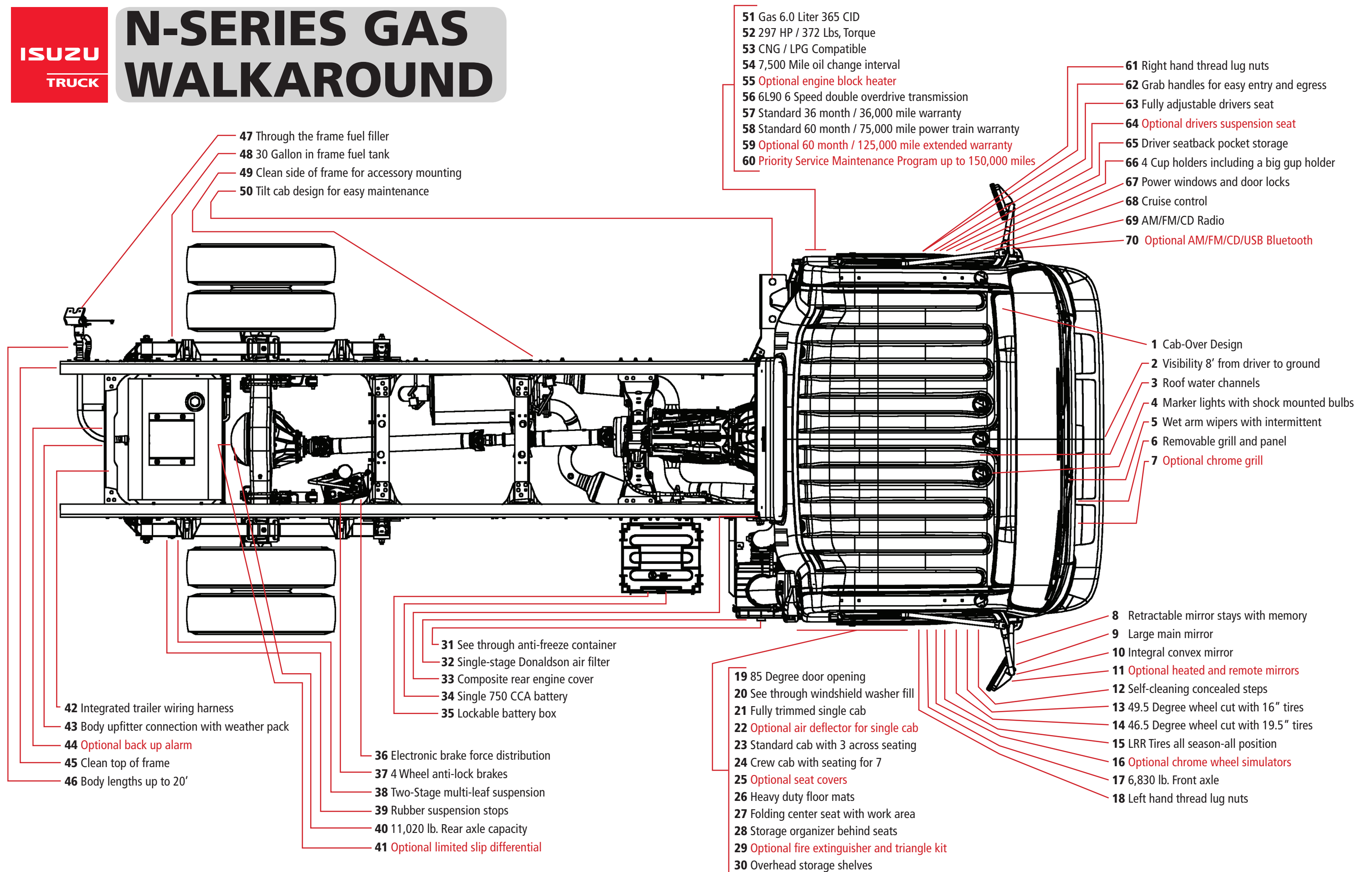

- 47 Through the frame fuel filler
- 48 30 Gallon in frame fuel tank
- 49 Clean side of frame for accessory mounting
- 50 Tilt cab design for easy maintenance

- 51 Gas 6.0 Liter 365 CID
- 52 297 HP / 372 Lbs, Torque
- 53 CNG / LPG Compatible
- 54 7,500 Mile oil change interval
- 55 **Optional engine block heater**
- 56 6L90 6 Speed double overdrive transmission
- 57 Standard 36 month / 36,000 mile warranty
- 58 Standard 60 month / 75,000 mile power train warranty
- 59 **Optional 60 month / 125,000 mile extended warranty**
- 60 **Priority Service Maintenance Program up to 150,000 miles**

- 61 Right hand thread lug nuts
- 62 Grab handles for easy entry and egress
- 63 Fully adjustable drivers seat
- 64 **Optional drivers suspension seat**
- 65 Driver seatback pocket storage
- 66 4 Cup holders including a big gup holder
- 67 Power windows and door locks
- 68 Cruise control
- 69 AM/FM/CD Radio
- 70 **Optional AM/FM/CD/USB Bluetooth**

- 1 Cab-Over Design
- 2 Visibility 8' from driver to ground
- 3 Roof water channels
- 4 Marker lights with shock mounted bulbs
- 5 Wet arm wipers with intermittent
- 6 Removable grill and panel
- 7 **Optional chrome grill**

- 42 Integrated trailer wiring harness
- 43 Body upfitter connection with weather pack
- 44 **Optional back up alarm**
- 45 Clean top of frame
- 46 Body lengths up to 20'

- 31 See through anti-freeze container
- 32 Single-stage Donaldson air filter
- 33 Composite rear engine cover
- 34 Single 750 CCA battery
- 35 Lockable battery box

- 36 Electronic brake force distribution
- 37 4 Wheel anti-lock brakes
- 38 Two-Stage multi-leaf suspension
- 39 Rubber suspension stops
- 40 11,020 lb. Rear axle capacity
- 41 **Optional limited slip differential**

- 19 85 Degree door opening
- 20 See through windshield washer fill
- 21 Fully trimmed single cab
- 22 **Optional air deflector for single cab**
- 23 Standard cab with 3 across seating
- 24 Crew cab with seating for 7
- 25 **Optional seat covers**
- 26 Heavy duty floor mats
- 27 Folding center seat with work area
- 28 Storage organizer behind seats
- 29 **Optional fire extinguisher and triangle kit**
- 30 Overhead storage shelves

- 8 Retractable mirror stays with memory
- 9 Large main mirror
- 10 Integral convex mirror
- 11 **Optional heated and remote mirrors**
- 12 Self-cleaning concealed steps
- 13 49.5 Degree wheel cut with 16" tires
- 14 46.5 Degree wheel cut with 19.5" tires
- 15 LRR Tires all season-all position
- 16 **Optional chrome wheel simulators**
- 17 6,830 lb. Front axle
- 18 Left hand thread lug nuts